

# FDT015

Fresa elicoidale antischeggia al diamante H4  
Per macchina bordatrice

Helical edgebanding anti-chipping tools pcd H4



CODE		D mm	B mm	d mm	Z=2+2 n° placchette
RIGHT Rot.	LEFT Rot.				
FDT015.001R	FDT015.001L	80	40	30	10
FDT015.002R	FDT015.002L	80	48	30	12
FDT015.003R	FDT015.003L	80	55	30	14
FDT015.004R	FDT015.004L	80	65	30	16
FDT015.005R	FDT015.005L	100	40	30	10
FDT015.006R	FDT015.006L	100	48	30	12
FDT015.007R	FDT015.007L	100	55	30	14
FDT015.008R	FDT015.008L	100	65	30	16
FDT015.009R	FDT015.009L	125	40	30	10
FDT015.010R	FDT015.010L	125	48	30	12
FDT015.011R	FDT015.011L	125	55	30	14
FDT015.012R	FDT015.012L	125	65	30	16

CODE		D mm	B mm	d mm	Z=3+3 n° placchette
RIGHT Rot.	LEFT Rot.				
FDT015.013R	FDT015.013L	80	40	30	15
FDT015.014R	FDT015.014L	80	48	30	18
FDT015.015R	FDT015.015L	80	55	30	21
FDT015.016R	FDT015.016L	80	65	30	24
FDT015.017R	FDT015.017L	100	40	30	15
FDT015.018R	FDT015.018L	100	48	30	18
FDT015.019R	FDT015.019L	100	55	30	21
FDT015.020R	FDT015.020L	100	65	30	24
FDT015.021R	FDT015.021L	125	40	30	15
FDT015.022R	FDT015.022L	125	48	30	18
FDT015.023R	FDT015.023L	125	55	30	21
FDT015.024R	FDT015.024L	125	65	30	24

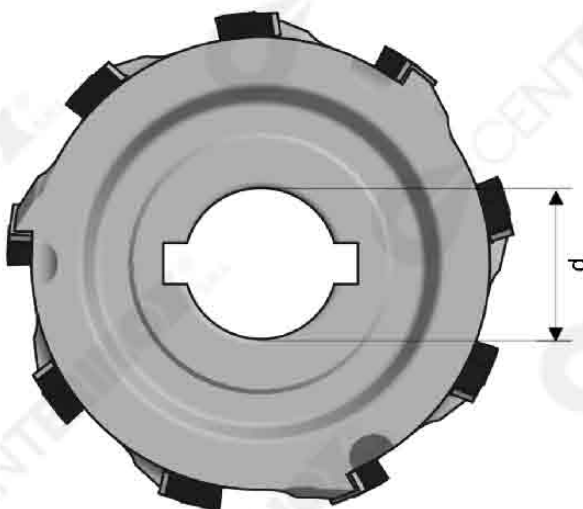
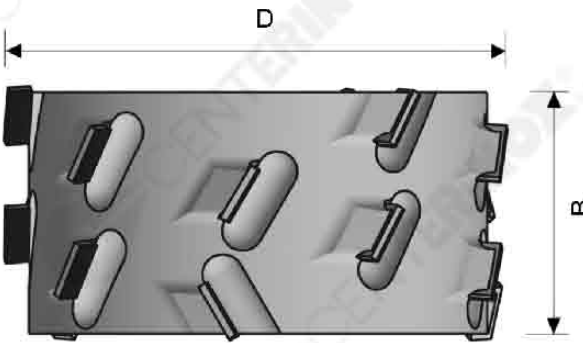

Rotazione destra  
Right rotation

Rotazione sinistra  
Left rotation