

# TPP41Q

Gruppo per sagoma di porte con bugna a infilare

CNC group for profile of doors without bead recovery

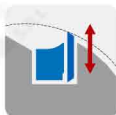
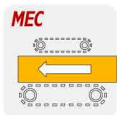

Utensile collaudato secondo la normativa  
Tool tested according to the norm

**EN 847-1**

CODICE CODE	D mm	A mm	Z
TPP41Q.001	135	HSK63-F - ISO30	2

CODICE CODE	PARTI DI RICAMBIO SPARE PARTS			Rif.
VRS6	VITE / SCREW	M5X7		F8
RSN2	RASANTE / SPUR	14X14X2		F8
GRN2DX-SX	VITE / SCREW	M6 - M6		F8
LR.1	CUNEO / WEDGE	7.3mm		F8
012L75	COLTELLO / KNIFE	7.5X12X1.5		F8
GRN1DX-SX	VITE / SCREW	M8-M6		F3-F7
OGV1SB	OGIVA / NUT	M8		F3-F7
T24SB	CUNEO / WEDGE	24mm		F3-F7
CLP41Q/A1	COLTELLO / KNIFE	25X35X2		F7
CLP41Q/A2	COLTELLO / KNIFE	25X35X2		F3
CLP41Q/B1	COLTELLO / KNIFE	25X35X2		F7
CLP41Q/B2	COLTELLO / KNIFE	25X35X2		F3
CLP41Q/C1	COLTELLO / KNIFE	25X35X2		F7
CLP41Q/C2	COLTELLO / KNIFE	25X35X2		F3
CLP41Q/D1	COLTELLO / KNIFE	25X35X2		F7
CLP41Q/D2	COLTELLO / KNIFE	25X35X2		F3

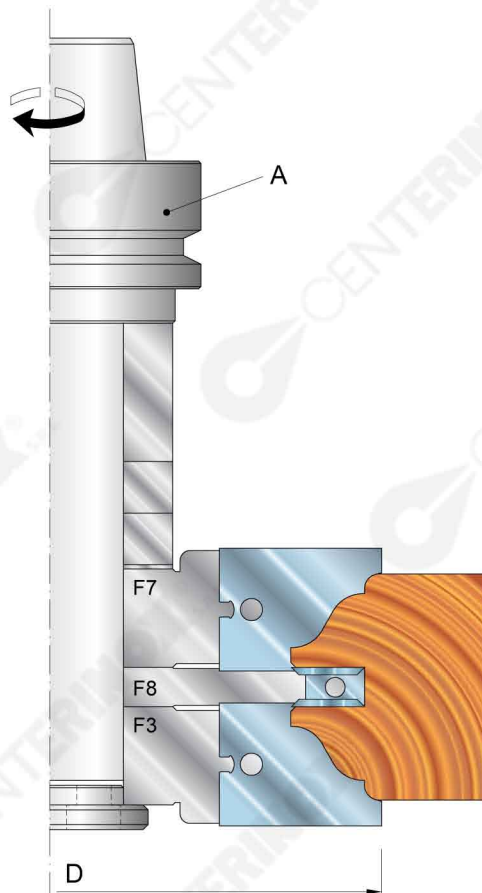

Un profilo a scelta / A profile to choice