

TPP41Q

Gruppo per controsagoma di porte con bugna a infilare

CNC group for counterprofile of doors without bead recovery



CODICE CODE	D mm	A/L mm	Z
TPP41Q.002	140	HSK63-F - ISO30	2

CODICE CODE	PARTI DI RICAMBIO SPARE PARTS		Rif.
VINS3	VITE / SCREW	M5X10	F6-F9
RGT3	INSERTO / INSERT	R3	F6-F9
GRN2DX-SX	VITE / SCREW	M6 - M6	F10
LR.1	CUNEO / WEDGE	7.3mm	F10
012L96	COLTELLO / KNIFE	9.6X12X1.5	F10
GRN1DX-SX	VITE / SCREW	M8-M6	F6-F9
OGV1SB	OGIVA / NUT	M8	F6-F9
T24SB	CUNEO / WEDGE	24mm	F6-F9
CLP41Q/A3	COLTELLO / KNIFE	25X35X2	F9
CLP41Q/A4	COLTELLO / KNIFE	25X35X2	F6
CLP41Q/B3	COLTELLO / KNIFE	25X35X2	F9
CLP41Q/B4	COLTELLO / KNIFE	25X35X2	F6
CLP41Q/C3	COLTELLO / KNIFE	25X35X2	F9
CLP41Q/C4	COLTELLO / KNIFE	25X35X2	F6
CLP41Q/D3	COLTELLO / KNIFE	25X35X2	F9
CLP41Q/D4	COLTELLO / KNIFE	25X35X2	F6

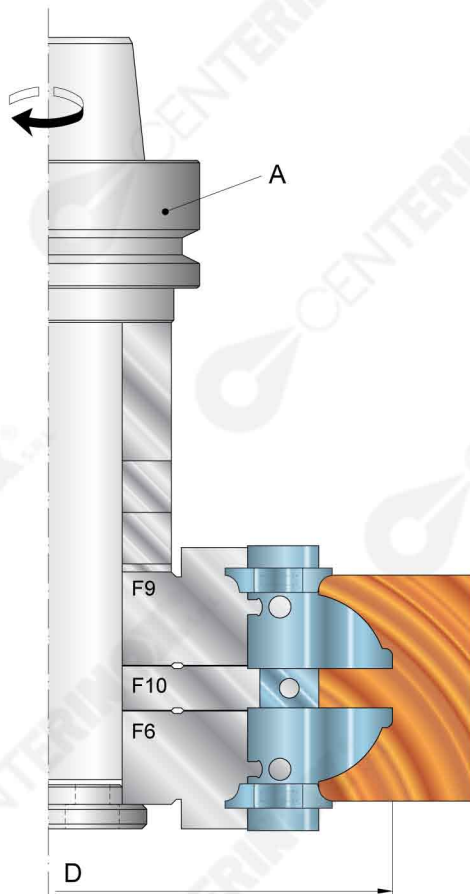

Un profilo a scelta / A profile to choice